

TECHNICAL DRAWING

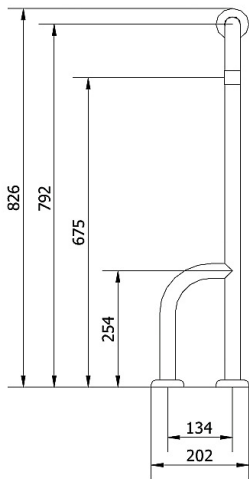

Particolare:
piattello di fissaggio
interno al rosone
N° 3 fori x Ø 6,3

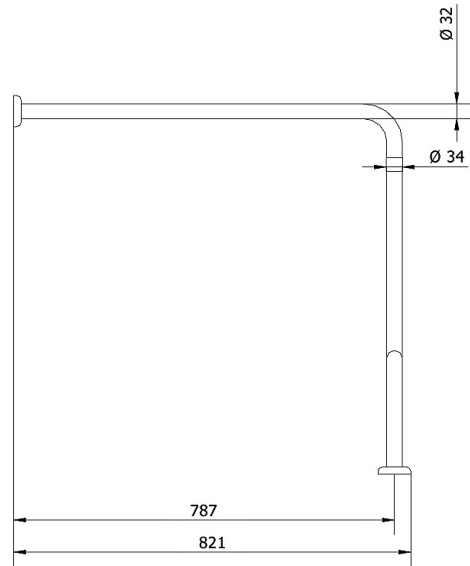

PHOTO



PRODUCT FAMILY: HANDBARS AND HANDRAILS – PAINTED SERIES
CODE: 800-I-B
DESCRIPTION: Wall-to-floor grab bar. Electrical insulation. White colour.

MECHANICAL PERFORMANCES:
Maximum load 150 kg.

APPROVALS/CERTIFICATIONS:
TUV system certification UNI EN ISO 9001:2008.
Declaration of Conformity according to European Medical Device Directive 93/42.
Reference regulations: Pr EN 1874; UNI EN 12182; UNI CEI EN ISO 14971; UNI EN 1041.

PRODUCT FEATURES:

Ø 32 cold bent body, complete with mounting flanges and flange covers. The outrigger must be mounted on the right- or left-hand side
The mounting flanges electrically insulate the product.
The article is partially assembled to reduce the overall dimensions during transport.

FIXING/INSTALLATION:

Finish assembling the product before mounting it.
Mounting by n° 9 plugs.
Plugs are not included in the package.
Read the instruction sheet to choose the suitable plugs according to the type of wall.

PRODUCT COMPOSITION:

N° 1 Pipe Ø32 x 15/10 - DC04 - Zinc-coated and painted RAL9016
N° 2 Mounting flanges Nylon PA6 RAL9016
N° 2 FLange covers Nylon PA6 RAL9016
N° 3 Fixing bushings Brass UNI EN 12164 CW614N
N° 3 Flange fixing screws Steel Tropicalized
N° 1 Sleeve - Brass Ø34x0,5 Painted RAL9016

MAINTENANCE:

Check the correct fastening of the accessories periodically.
Perform a proper cleaning with water and soap, do not use abrasive or corrosive agents or coarse sponges.

TOLERANCES:

0÷300 ±3 301÷600 ±4 601÷2000 ±5

PACKAGING OF THE PRODUCT:

Wrapped in bubble wrap.
Weight: 3 kg

ST_PRODOTTO:800-I-B - 1	APPROVATO R.T.
REV.00 DEL 25/09/09	

